

LEADERSHIP DEVELOPMENT

PROJECT PLANNING FOR MINISTRY LEADERS

by David Stiles

PARTICIPANT GUIDE



Project Planning for Ministry Leaders

by David Stiles

Participant Guide

About the Author

David Stiles works as a writer and consultant for churches and other organizations. He is the author of *“Skills for New Leaders: A Turbo Group Training Program”*, *“Discovering Small Groups”*, *“Discovering the Gift of Leadership”* and other training programs used by churches.

In addition to serving in part-time and volunteer roles for churches, Dave has served as a project manager and consultant on a number of technical and corporate projects for Fortune 500 companies.

Copyright Information

Copyright © 2005 David J. Stiles. All reproduction or transmission in any form or by any means, electronic or mechanical, including photocopying, recording, storage in an information retrieval system, or otherwise, may not be done without the prior written permission of the author.

For Additional Information

 Web Site

www.dstiles.com

Contents

Chapter 1: Introduction	6
Chapter 2: What is a Ministry Project?	12
Chapter 3: Assessing Your Project Leadership Skills	28
Chapter 4: Project Chartering	36
Chapter 5: Project Planning – Identifying Major Objectives.....	54
Chapter 6: Project Planning – Identifying Tasks	78
Chapter 7: Project Execution and Monitoring.....	107
Chapter 8: Closeout	121
Chapter 9: Project Leadership	130

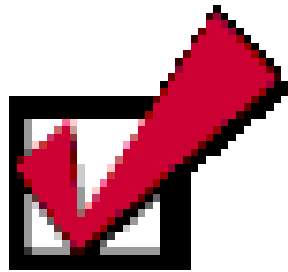

Introduction

In this chapter you will:

- Get to know others
- Learn key features about "Project Planning for Ministry Leaders"

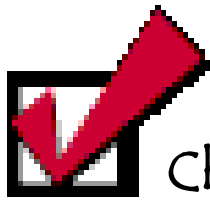

Chapter 1: Introduction

Welcome...

Welcome to "Project Planning for Ministry Leaders". During this training you will learn helpful concepts for creating and managing ministry projects. In the training you will:

- ✓ plan for a ministry project in your church or ministry organization
- ✓ assess your project leadership strengths and growth areas
- ✓ plan to effectively communicate goals and plans
- ✓ utilize project methodology for a ministry project

Our Tools...

Throughout our training we will use a variety of methods to learn about ministry projects, including:

- ✓ Practical insights on projects
- ✓ Group discussion questions
- ✓ Personal reflection questions
- ✓ Prayer

Why Project Training?

As a ministry leader, you will encounter many _____ throughout your work in ministry. They may be _____ in scale, such as constructing a building, or something _____, such as starting a small group. It can be helpful, therefore, to understand the dynamics of projects and utilize project skills to accomplish your goals. The project management skills taught in this training are typically not taught in Seminary or Bible College but can be acquired through experience, research, reflection and prayer on these important topics.

Assumptions...

The models that we will follow for managing projects are widely accepted in many organizations. However, it is important for us to always remember that Jesus desires to be the _____ of our life and of our work. We need to always be open to His wisdom and direction. Christ is seeking followers who will be obedient to Him. If He is calling you to do things in a unique way, then you need to be open to His will and follow Him.

Another important point to keep in mind is that in spite of our efforts to work hard and plan diligently, we need to remember to leave the _____ of ministry up to God.

Opening Prayer...

Lord, thank you for the many gifts that you provide. Lord, we humbly ask for Your wisdom as we consider how to best help others in ministry. Help us always remember that You are the reason for ministry. Help us serve others in a way that glorifies You. Amen.

Questions for Discussion

1. Introduce yourself to others. From the list below, identify what makes you most excited about doing ministry. Why?

- Serving God
- Helping families
- Helping people in need
- Seeing my church grow
- Seeing people change
- Other: _____

2. What three things would you like to gain from this training course? Why?

Personal Reflection

1. What is the most rewarding aspect of doing ministry? Why?

2. What has been the most challenging aspect of doing ministry? Why?

3. Of the things that you would like to gain from this training program, which one is the most important to you? Why?

Notes



What is a Ministry Project?

In this chapter you will:

- Utilize a definition of a ministry project
- Identify common phases of a ministry project

Chapter 2: What is a Ministry Project?

Ministry...it's a word that is used frequently by Christians. It can refer to many things, but typically it means _____ God and being _____ by Him to help others.



Many things that Christian leaders do in ministry (whether it is launching a small group, starting a new ministry or constructing a building) can be viewed in terms of a ministry "project".

Each ministry project is unique. Each has both fascinating and challenging elements to them. Some ministry projects may be very _____ and done quickly while others may be very _____; requiring you to respond to sudden changes and unforeseen events.

A ministry project is first and foremost ministry...it is something done to serve _____ and help _____. Each ministry project is unique, but should be inspired by God for the benefit of others.

It is also a project....it is defined work with a _____ and an _____.

Definition:

A ministry project is work focused on specific purposes to serve God and help people within a defined scope.

Ministry projects may be large or small in _____. They may affect a few people, a neighborhood or many people.

For example, your ministry project might be:

- Constructing a building
- Starting a new church service
- Conducting an overseas missions trip
- Starting a small groups ministry
- Starting a ministry to the poor
- Starting a neighborhood small group
- Raising funds for a Christian school

What is the role of a ministry leader on a ministry project?

To help accomplish our ministry projects, we will focus on models and _____ that are generally accepted project management practices.

Definition:

Project management is the process of leading, planning, and organizing a project.

If you are new to leading a ministry project, you might be asking yourself several important questions, such as:

- What potential do I have for managing ministry projects?
- Does God really want me to lead ministry projects?
- What difference can I make in a ministry project?
- How could I best serve on a ministry team?

These are important questions, and the answers need to be prayerfully considered. This training program is designed to assist you as you consider these and other important questions.

Four Insights on Ministry Projects

As you pursue leadership of ministry projects keep the following in mind:

1. Be careful of the things that can get you off _____.

Jesus desires _____. He desires that we keep our thoughts on Him. He desires that we continually seek Him, His direction and His wisdom. Unfortunately, circumstances in life can get our thoughts on other things.

One pattern that is typical in ministry is the following:

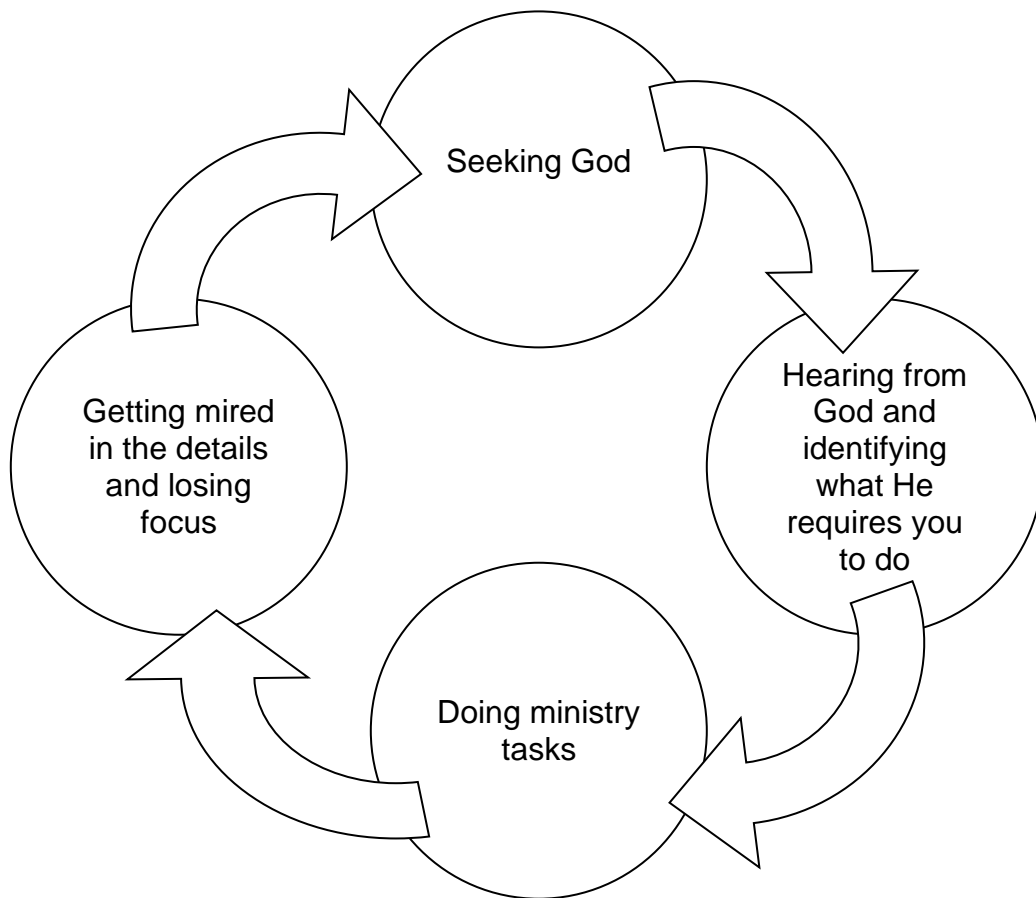

The critical point in this pattern is "losing focus". Therefore, it is important to look for ways to keep God first.

Four Insights on Ministry Projects, continued

2. Know that implementing ministry projects can be

_____.

It is common for issues to arise when doing ministry projects. There are several reasons for issues or difficulties:

- ✓ _____ are involved
 - people are sinful
 - people have different norms, values, personalities, preferences and styles
 - most people working on ministry projects are volunteers (and may have a limited amount of time to spend on the project)

- ✓ We have an _____

Our spiritual enemy is committed to thwart God's plans. The apostle Paul, however, was able to say with confidence to Timothy that "the Lord will rescue me from *every* evil attack and bring me safely to his heavenly kingdom" (II Timothy 4:18)

- ✓ _____ are involved
 - we are sinful (we can be proud, jealous, etc.)
 - we are not perfect (in our skills, in our communication abilities, in our leadership)

Four Insights on Ministry Projects, continued

3. Understand that _____ is happening

Something will be changing by the very nature of implementing a ministry project. You may be asking people to commit to something _____ and different as an existing ministry is replaced or modified or as a new ministry opportunity is offered.

Although we will be focusing much on thinking and planning throughout this course, it is essential that we consider people's _____ and the ramifications of change.

Some people will eagerly adopt the change, while others may be very resistant.

There are many different responses to change:

- Resistance
- Tolerance
- Accommodation
- Assimilation/Adoption

It is important to understand that people will respond in different ways to a ministry project and _____ for these responses.

Four Insights on Ministry Projects, continued

4. Know that people will have different _____ about a ministry project.

It is important to consider people's _____ regarding a ministry project.

The following scale describes four responses to a ministry project: unawareness, unrealistic hopes, disappointment and realistic expectations. Some people may experience all four of these expectations, while others who encounter your project may remain in one area and not move to the next area. It is important to plan for these different expectations.

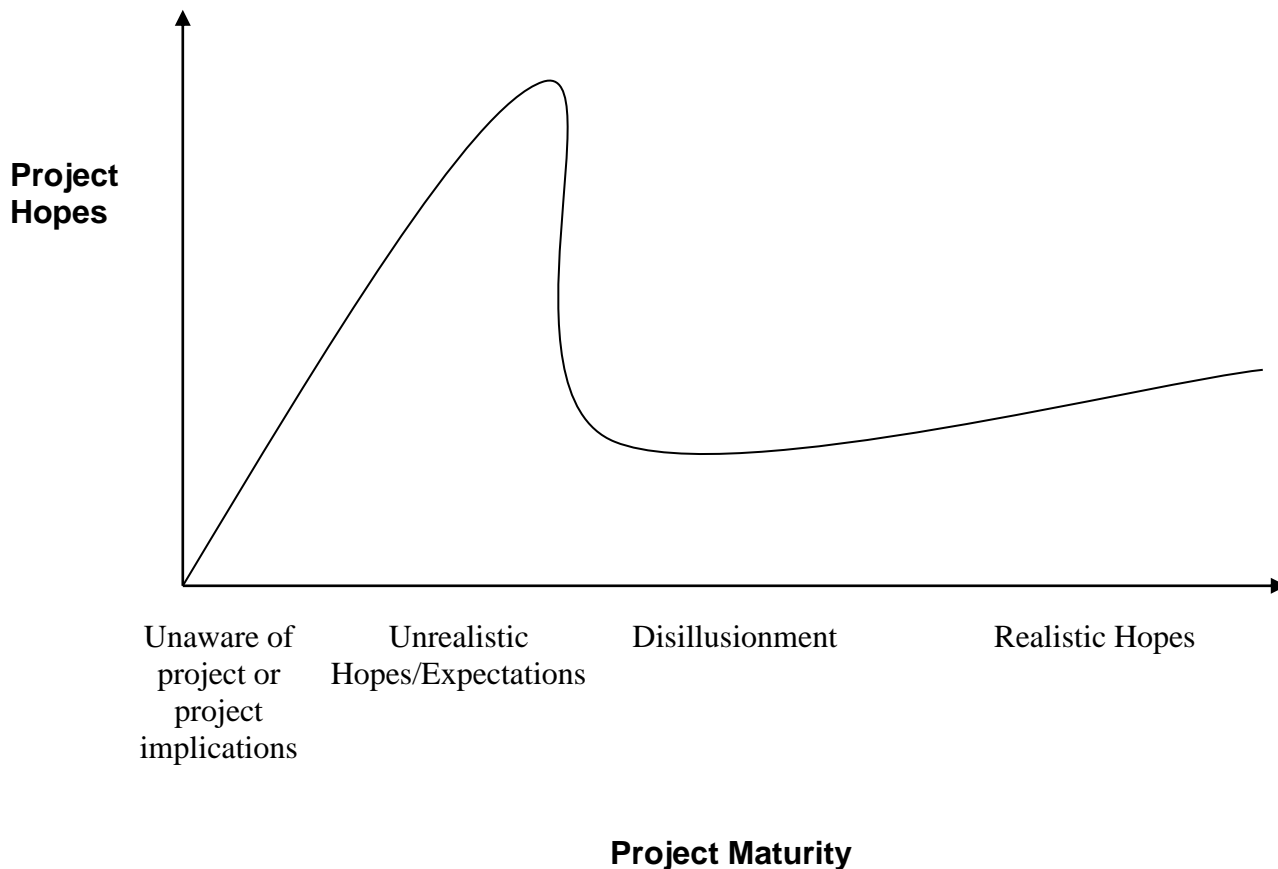

Questions for Reflection

1. What are the things that get you "off track" in ministry?

2. What difficulty have you seen when working with projects?

3. How do you respond to change?

4. How have expectations played a positive or negative role in ministry?

A Model for Ministry Projects

The following model can be helpful as you consider leading a ministry project. It is important to remember that each ministry project is _____ and time spent on each phase will vary by the complexity of the project. It is also important to remember that Christian ministry involves a dialog with _____...seeking His direction and wisdom in prayer. If there are things that are unique that He is calling You to do, You should follow His will and direction.

Although each project is different, it is important to consider five distinct project phases:

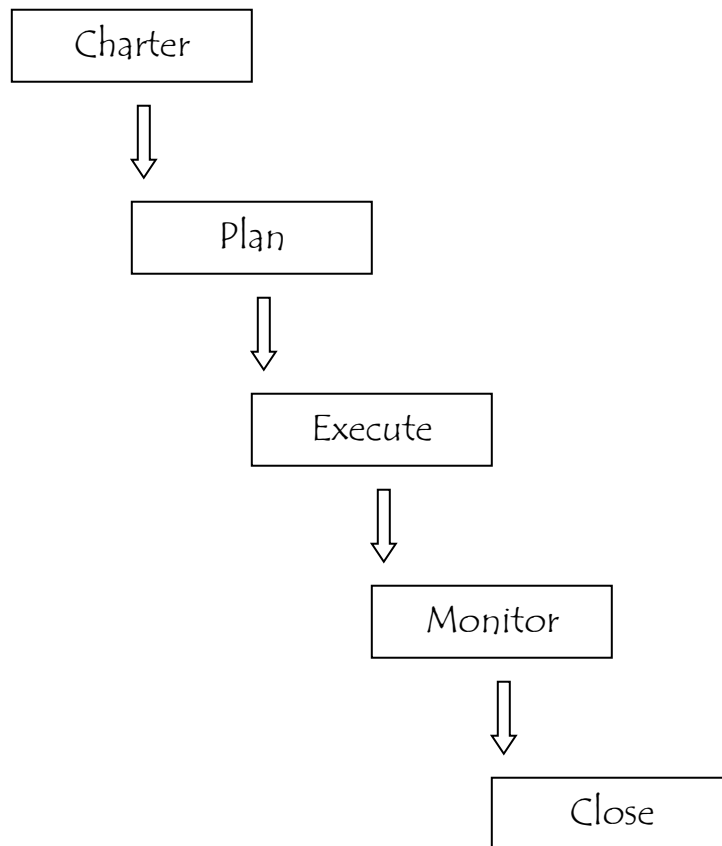

Phase 1: Project Chartering

The project chartering phase involves _____ your ministry project. Important elements of this phase include identifying who will be served by the ministry project and what need(s) will be addressed, establishing the project's scope and identifying project team members.

Phase 2: Project Planning

The project planning phase involves the creation of a plan for the ministry project. This plan identifies the necessary tasks and resources for completing the project and a _____ for when they will be accomplished.

Phase 3: Project Execution

The project execution phase of a ministry project involves the _____ of one or many people to accomplish the tasks that were planned. For project leaders, coordinating people and resources will be very important during this phase.

Phase 4: Project Monitoring

The project monitoring phase of a ministry project involves _____ the project based on planned objectives and measures.

Phase 5: Project Close

The project close, or closeout, phase of a ministry project involves _____ the project and reviewing accomplishments and lessons learned.

The Project Model in Real Life

Put into action, the above phases of a ministry project will not neatly fit into five separate and distinct phases.

It is important to note that projects will change based on _____ circumstances. In some cases, elements of a ministry project will be repeated as you work toward your project's goals. The following is an example of what might occur:

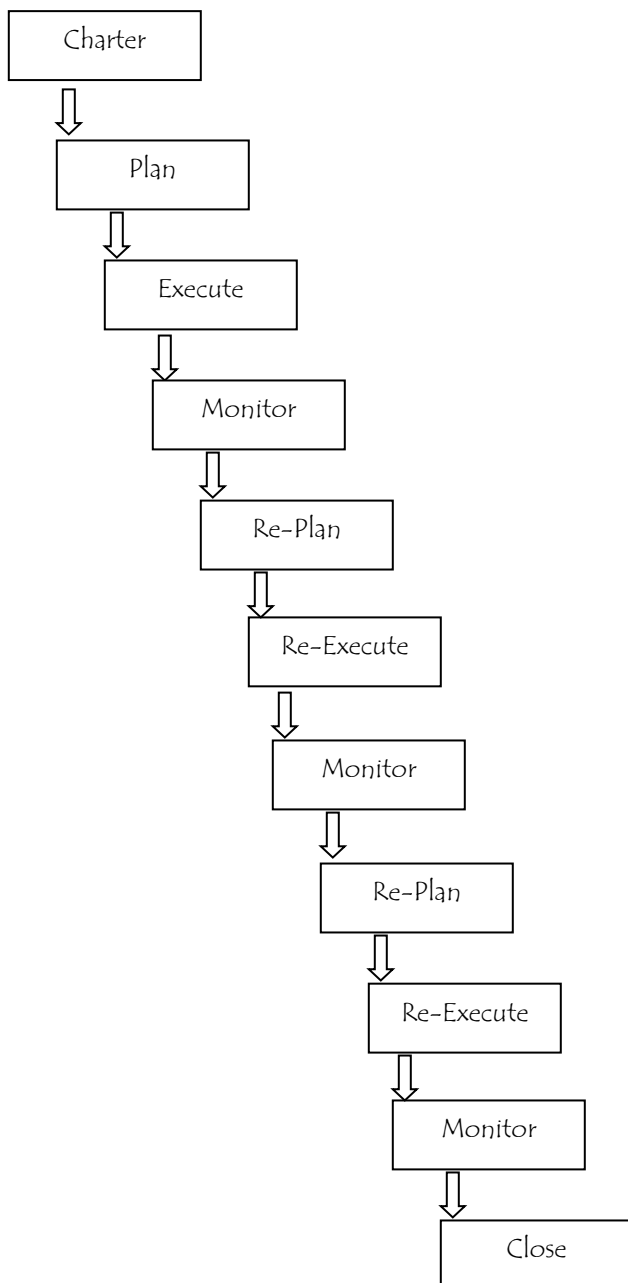

Questions for Discussion

1. Reflect on a ministry project that you considered successful.

a. How did you feel about the project?

b. What things made the project go well?

c. What did you learn?

2. Reflect on a ministry project that did not go well or failed.

a. What were your feelings toward the project?

b. What things contributed to the project's failure?

c. What did you learn?

3. What benefits might people find as they participate in a ministry project?

4. What areas of a ministry project would you like to learn more about?

Personal Reflection

1. What word best describes your feelings about ministry projects? Why?

- Confused
- Excited
- Cautious
- Other: _____

2. Reflect on your experience with ministry projects. What was the easiest part about planning or implementing these ministry projects? Why?

3. What have been the most difficult parts about planning or implementing ministry projects? Why?

Notes

Assessing your Project Leadership Skills

In this chapter you will:

- Answer questions about your project leadership skills
- Learn four important elements of project leadership



Chapter 3: Assessing Your Project Leadership Skills



There are several important ways that leaders can help a ministry project successfully reach its goals. The assessment that follows is designed to assist you in analyzing your skills.

Instructions:

On the following pages you will be asked to complete seven sentences regarding your project management skills. Each sentence has four endings.

Rank the endings for each sentence according to how well you think each one fits you. Rank a "4" for the sentence that best describes your project leadership skill, down to a "1" for the sentence that least describes your project leadership skill.

Place your score for each response on the line that follows each question.

Remember:

- 4 = most like your project leadership skill
- 3 = second most like your project leadership skill
- 2 = third most like your project leadership skill
- 1 = least like your project leadership skill

Use each number only once as you complete each sentence.

Project Leadership Analysis

Remember:

- 4 = most like your project leadership skill
- 3 = second most like your project leadership skill
- 2 = third most like your project leadership skill
- 1 = least like your project leadership skill

Use each number only once as you complete each sentence.

	Response
1. As a ministry project leader, the most important area I should focus on is managing the project's :	
a. people resources.	
b. budget.	
c. schedule.	
d. quality.	

	Response
2. When starting a ministry project, I think I should ensure that:	
a. the right people are available for the project.	
b. the project is fully funded.	
c. the project can be done on time.	
d. clear standards are set for project outcomes.	

Project Leadership Analysis, continued

	Response
3. I am best able to solve issues involving:	
a. people on the ministry project.	
b. project funding and costs.	
c. project scheduling.	
d. project standards.	

	Response
4. I'm motivated to:	
a. recruit and train the right people for the ministry project.	
b. acquire funding, discover cost savings and live within the project budget	
c. meet and exceed timing requirements.	
d. meet and exceed project expectations by others.	

Project Leadership Analysis, continued

	Response
5. I'm best at communicating:	
a. people's roles and responsibilities on the project.	
b. the financial needs for the project.	
c. a sense of urgency in getting things done.	
d. clear standards for project success.	

	Response
6. I will avoid at all costs:	
a. wrong people working on the project.	
b. the project being over budget.	
c. the project being late in providing services or implementing it's goals.	
d. shoddy workmanship or low quality.	

Project Leadership Analysis, continued

	Response
7. For me, a successful project happens when the project's : a. team feels that it has accomplished something worthwhile.	
b. expenses are equal to or under what was budgeted.	
c. tasks have been done early or on time.	
d. expectations are exceeded.	

Your Project Leadership Preferences

In our training, we will explore four important ways that Christian leaders can help manage ministry projects. The sentences you have completed above relate to how it is necessary for leaders to:



- ✓ Manage _____ who are working within the ministry project.
- ✓ Manage the ministry project's _____, to help ensure financial responsibility.
- ✓ Manage the ministry project's _____, to ensure that tasks are on track and on time.
- ✓ Manage the ministry project's _____, to ensure that things are done right and in an acceptable manner.

We will explore each of these four areas as we look at the various phases of a ministry project.

Total the scores from each line and enter the total on the lines below:

Totals for Line A (People): _____

Totals for Line B (Budget): _____

Totals for Line C (Schedule): _____

Totals for Line D (Quality): _____

Notes

Project Chartering

In this chapter you will:

- Discover important components of the Project Chartering phase of a ministry project



Chapter 4: Project Chartering

We noted earlier that there are typically five distinct phases to a ministry project:

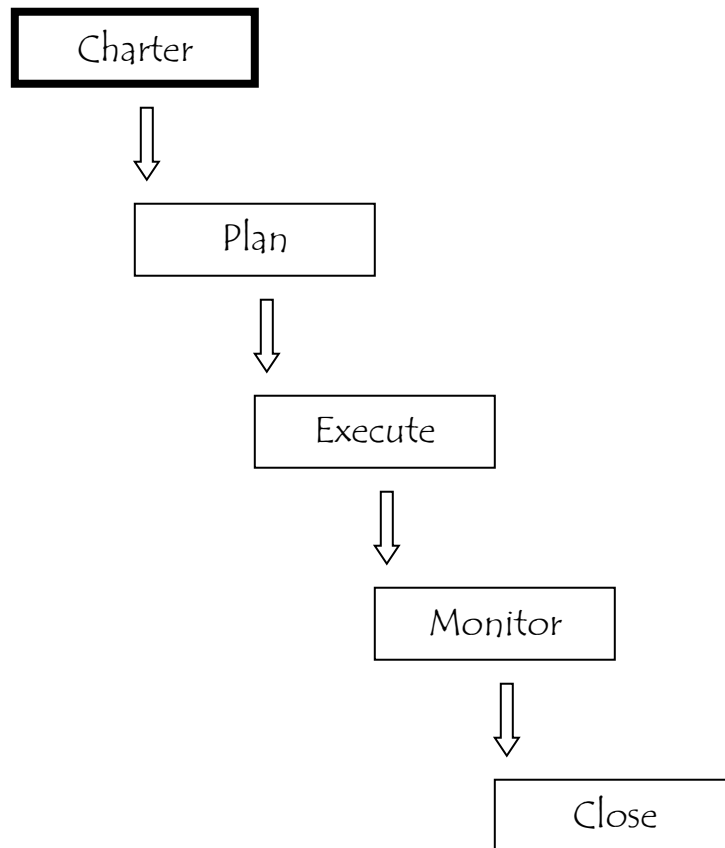

In this chapter we will explore the Project Charter phase.

Project Charter Overview

The project charter phase involves clearly _____ the Ministry Project. In this phase you will answer the following about the project:

Identify the _____
served by the
project

W _____

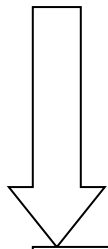

Identify the
_____ behind the
ministry project

W _____

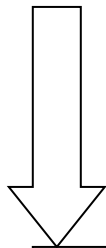

Identify project

W _____

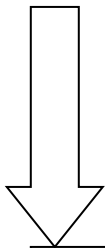

Identify the
project _____ and
stakeholders

W _____

Identifying the People served by the Project

The first step in starting your ministry project is answering an important question about the project:

Who is God calling you to serve?

It is essential that you identify the _____ audience that God is calling you to _____.

We find in Scripture a number of examples of leaders who were given a vision from God to help people:

- ✓ Paul – had a vision to evangelize the non-Jewish world
- ✓ Moses – had a vision to see God free the Hebrews from slavery and lead them to the Promised Land
- ✓ David and Solomon – had a vision to follow God and build a Temple for the Lord
- ✓ Nehemiah and Ezra – had a vision to rebuild the walls of Jerusalem and the Temple

God may be calling you to:

- ✓ Serve people in your neighborhood
- ✓ Serve the poor or homeless in your city
- ✓ Serve families in your community

It is important to clearly identify who God is calling you to _____.

Note: There may be multiple audiences that you feel called to work with. If there are multiple audiences, it can be helpful to specifically identify each group.

It is important to understand as much as possible about those God is calling you to serve, such as:

- Geographic
- Demographic
- Values
- Beliefs
- Economic Issues

During the chartering phase, it may only be possible to answer these questions in very generic terms. However, even though your responses may be very general it still will be helpful for your project team. Later, more information can be gathered and your assumptions can be verified.

Prayer Points:

1. Pray for understanding in identifying who God is calling you to serve.
2. Pray for those that will be impacted by the ministry project.

Questions for Discussion

1. Who is God calling you to serve?

2. What do you know about the people that God is calling you to serve?

Geographic

Where do they live?

Demography

What is their age?

Values

What is important to them?

Beliefs

What do they believe?

Economic

What financial challenges or opportunities do they face?

3. What additional information do you need to have in order to know more about those that God is calling you to serve?

Identifying the need for the Project

The next step in the Chartering Phase of your ministry project is to identify:

W____ are you doing the project?

During this step, it is important to identify the existing _____ of those that you are called to serve and to identify why God might be calling you to meet those specific needs.

As you identify the current needs of those that God is calling you to, it is also helpful to identify any other reasons why you are doing your project.

Prayer Points:

1. Pray for those your project is to serve.
2. Ask God to help you understand the needs or the pain of those who will be served by the project.
3. Ask God to give you wisdom as to why He is calling you to meet those specific needs.

Questions for Discussion

1. What are the needs of those you are called to serve?
2. Why are those needs best met by your project?
3. Why might God be calling you to this area?
4. Are there any other reasons for doing the project?

Identifying Project Outcomes

The next step in the Chartering Phase of your ministry project is answering:

W_____ will be accomplished with the ministry project?

As you consider the project that God is calling you to implement, it is important to identify what the " _____ state" will be once the project is complete. Another way of saying this is, "What does success look like for our project?"

As you consider a successful project, the most important consideration for a ministry project, is the _____. You must prayerfully consider how God defines success for your project.

As Paul wrote in First Corinthians 13, outward success means nothing if it is different than how the Lord defines success.

You should prayerfully consider your own opinions too. How do _____ define a successful project? How might it be different than the opinions of others.

It is also important to identify how _____ define the success of the project, including the project team, stakeholders (people who are helping the project succeed), and others who are helping with the project.

Finally, you should consider those who are being _____. If the project is a success, how will they feel? What will they do differently than what they are doing now? How could the lives of others change because of the project?

Prayer Points:

1. Pray for wisdom regarding the project outcomes.
2. Ask God to help you understand His definition of success for the ministry project.

Questions for Discussion

1. Complete the following sentence about the overall mission or vision of your project.

"Our project will serve God and help people by

2. What specific things could be accomplished by the completion of the project? Write these objectives on page 90 of your manual.

3. How does God define success for your project?

4. How would project stakeholders define success?

5. How will the project be measured?

6. Describe the gap that exists between how things are now and how they will be at the end of the project.

Identifying the Project Team

The next step in the Chartering Phase of your ministry project is identifying:

W_____ is God calling you to serve with?

In Scripture we see many examples of people _____ to accomplish God's purposes:

- Jesus and his disciples
- Paul with Timothy
- Moses and Joshua

It is important, therefore, not to work alone in your ministry project but to engage _____. It can be helpful to identify what areas of interest, passion, gifting, talent and skill each team member has in terms of the project.

Not only is it important to understand the unique contributions that each team member might bring, but to also identify their values and understand what they see as important.

Note: It is also important to note that as the project progresses others might be needed on the project team.

Creating a preliminary list of other volunteers that might help with the project can also be helpful.

Values

There are many expectations that people have when joining a project team. It is important to identify what is important to each team member.

A_____ – people feel free to share their concerns and make mistakes

A_____ – attending team meetings as often as possible

A_____ – being yourself around others

A_____ – making time for others on the team and for accomplishing project goals

C_____ – doing agreed upon tasks

C_____ – avoiding gossip or sharing team member's personal information outside the group

H_____ – speaking the truth in love

L_____ – seeking to understand the concerns of others

O_____ discussion within the project team

P_____ – everyone is actively involved

R_____ – communication is done in ways that communicate a consideration for others

Decision Making

After establishing a project team, it is also important to identify how _____ will be made.

There are many ways teams can make decisions. It is important to identify the process on how these decisions will be made. Such as by:

- consensus
- vote
- a senior person

You will also need to consider if it is necessary to have _____ agreement from the entire project team.

Prayer Points:

1. Pray for wisdom regarding those that God is calling you to serve with.
2. Pray for protection from spiritual warfare and attack as you seek to serve God together.
3. Pray for unity in Christ among the team.

Questions for Discussion

1. Who has God called you to serve with? Name each individual and list their gifts/skills/talents that they could bring to the project:

Initial Project Team	
Team Member Name	Areas of Interest (Gifts/Talents/Skills)

2. List others who also might serve on the project (as volunteers, etc.)

Other Individuals	
Volunteer	Areas of Interest (Gifts/Talents/Skills)

3. What values are important to the team?

4. Ideally, how will decisions be made?

Chapter Review

Next Steps:

1. Meet with your Ministry Project team.
2. Review the initial project concept.
3. Identify the people served by the project.
4. Identify the need for the project.
5. Identify initial project objectives.
6. Identify the initial project team and clarify team values and initial roles.

Questions for Discussion:

1. How can a project chartering phase be helpful?

2. Read the following scenario:

Recently, a pastor met with a member of their congregation. "Pastor," the parishioner said. "I have a lot of energy to start a small group ministry in the church. What should I do to get started?"

What recommendations would you give to the pastor and the parishioner?



Project Planning

In this chapter you will:

- Discover important components of the Project Planning phase of a ministry project

Chapter 5: Project Planning

We noted earlier that there are typically five distinct phases to a ministry project:

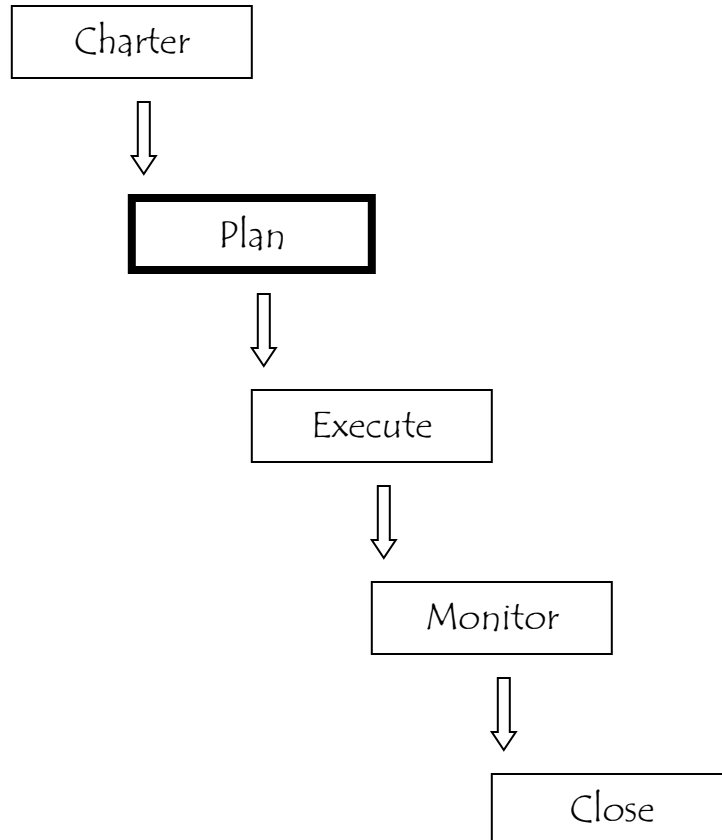

In this chapter we will explore the Project Planning phase.

Project Planning Overview

This phase involves _____ a plan to accomplish the ministry project.

In this phase you will answer the following about the project:

Confirm the major ministry project

W_____



Identify the necessary _____ for each objective

H_____



Identify _____ for each project task

W_____



Identify the _____ needed for each task

W_____

Confirm the Major Ministry Project Objectives

The first step in planning your ministry project is to ask:

W_____ are the major objectives of the project that will accomplish the overall project goal?

It is essential that you identify the major _____ to accomplish the overall project _____. These objectives should be developed with the project team and other project stakeholders.

The objectives that you identify should be:

- ✓ Attainable
- ✓ Measurable
- ✓ Consistent with other objectives of the project

For example, if the goal (or vision) of your ministry project is to start a small group, major objectives for the project might be to:

- ✓ Identify a location
- ✓ Select curriculum
- ✓ Invite participants
- ✓ Start the small group

Prayer Points:

1. Pray for wisdom in identifying the major objectives of your project.
2. Pray for wisdom in building your project plan.

Questions for Discussion

1. Review your overall project vision statement from page 46. Update the statement if anything has changed since it was initially created.

"Our project will serve God and help people by _____

_____."

2. Discuss the major objectives for your project. Review the major project objectives already identified on page 90. Add any additional objectives to the worksheet on page 90.

Establish Additional Project Objectives

In developing your project plan, you should consider planning for the following:

- ✓ A_____ – to confirm that the project is approved
- ✓ R_____ – for gathering additional information
- ✓ C_____ – for telling others about the project and keeping team members and stakeholders informed
- ✓ B_____ – to estimate and control project costs
- ✓ R_____ –for mitigating or minimizing issues that might get the project off track
- ✓ Q_____ – for ensuring that things are on-track
- ✓ C_____ – for unexpected events

For each of these areas (if applicable to your project) you should establish broad objectives, and then identify the specific tasks necessary to accomplish each objective (which we will cover in the next chapter).

Authorization

Depending on the scope and scale of the ministry project and your church's organizational structure, your project may need to be:

- approved by a senior _____ within your church
- approved by a _____ within your church
- voted on by your _____ congregation
- approved by a leader _____ your local church

Those authorizing and approving a project are referred to as the "project sponsors". Sponsors can serve as advocates for the project and may need to approve the:

- initial project concept
- budget
- launch of the entire project
- launch of major pieces of the project
- communication pieces

It may also be necessary to do thorough research or create a prototype prior to the broader project being authorized.

You will want to include any steps necessary for project _____ in your project plan.

Prayer Points:

1. Pray for the sponsors of your project.
2. Pray for clarity around the process to authorize the project.
3. Pray for unity in Christ among the team and project sponsors.

Questions for Discussion

1. How are projects authorized in your church or ministry organization?
2. Who will be approving your project to proceed?
3. What communication will be necessary with the project sponsor?
4. Should authorization be an objective in your project plan? If so, place it on the worksheet found on page 90.

Research

It may be necessary (especially if you are working with a very large scale project) to gather quantifiable _____ before proceeding into certain stages of your project.

This information typically comes from those your project will be serving, although it may also come from project stakeholders and the project team.

You may need to:

- ✓ Identify research _____
It may be necessary to identify pertinent topics to research.
- ✓ Develop research _____
You may need to identify the necessary tool to use: survey, focus group, etc. Then, develop interview questions for surveys or other tools.
- ✓ Conduct the _____
You may need to conduct interviews with your target audience to understand points of view, perceptions, expectations and needs.
- ✓ Synthesize and validate _____
You may need to compile the research findings to uncover recurring themes and ensure that findings are in line with project goals.
- ✓ Communicate research _____
A final task may be to communicate research results to the project team and project stakeholders.

Prayer Points:

1. Pray for understanding regarding those you will be serving.
2. Pray for wisdom in uncovering needs and assumptions regarding those who will be served and those who will be serving on the project.

Questions for Discussion

1. What areas would like to know more about for your ministry project?
2. What steps could your team take to find this information?
3. Should research be an objective in your project plan? If so, place it on the worksheet found on page 90.

Communication

Problems with communication are one of the main causes for projects to fail. You will want to include communication objectives in your project plan for telling others about the project and for keeping team members and stakeholders informed.

Communication Audiences

There are generally two different types of audiences for a project:

- _____ Audience

- _____ Audience

An internal audience includes members of your project _____ and project stakeholders (people who are helping the project succeed). You will need to determine the _____ that they will need to be communicated with (i.e. once a week, month, etc.) and by what _____ (email, etc.)

The external audience consists of people _____ of your project team. An external audience will include those your project will be serving and others impacted by the project.

It is important to note that different audiences may need different types of information.

Communication Phases

There are generally _____ important phases that you will want to plan for as you consider your project plan. These phases relate to a participant's _____ with the ministry project:

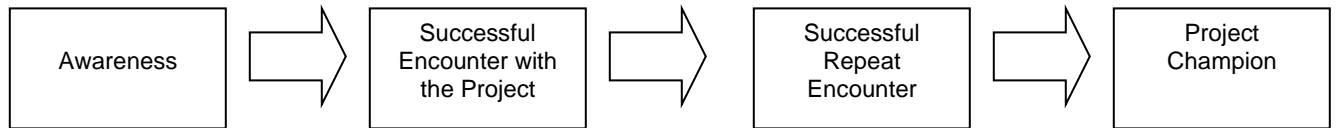

Phase	Description
Awareness	Participants know _____ the ministry project or project deliverables.
Successful Encounter	Participants have a positive _____ with the project.
Successful Repeat Encounter	Participants interact with the project _____.
Project Champion	Participants have such positive feelings for the project or project deliverables that they _____ many people about the ministry project.

It is important to consider _____ four phases. As you plan, carefully look at your assumptions about learning and communication to ensure that you are not focusing on only one or two of these areas.

Communication Tasks

As you plan for communication needs in your project plan, you may need to consider the following tasks:

- updating the project's "vision statement" (found on page 46) to clearly identify project benefits and main concepts in a language that participants understand

- creating a project name

- creating a project "tagline" (which can help immediately identify the project)

- creating a visual identity (logo, templates, guidelines, etc.)

- creating a communication strategy for internal and external audiences (that defines your approach for moving people from the Awareness, to a Successful Encounter, to a Successful Repeat Encounter to Project Champion).

The options available for moving people from one stage to another are endless, such as:

- education/training
- advertising
- newsletters
- direct mail
- sermons
- Church announcements
- personal invitations
- successful adoption by leaders

Prayer Points:

1. Pray for wisdom regarding the best way to communicate to those on the project team.
2. Pray for wisdom regarding the best way to communicate to those you will be serving.

Questions for Discussion

1. What words describe your project?
2. What might be the best method for communicating the project to others?
3. Should communication be an objective in your project plan? If so, place it on the worksheet found on page 90.

Budget

A budget will be necessary for most ministry projects. A budget allows project sponsors and project team members to know the estimated costs for the project. A budget can also be helpful if fundraising efforts are necessary.

There are several considerations in working with a project budget:

- ✓ Create a cost estimate for each _____
To create a project budget, you will need to identify each task involved in the project (covered in the next chapter) and create a cost estimate for the resources needed to complete each of these tasks. Essentially, you will be asking, how much will it cost to do what we want to do?
 - One way to do this is to look at previous projects that may have been done by your church or ministry.
 - For more complex projects, computerized tools are available to do cost estimates.
- ✓ Create a Budget _____
Next, you may need to create an estimate for the overall project budget.
 - For more complex projects, you may need to identify phases of when funding will be necessary. Therefore, you will need to look at the project timeline to identify when costs will need to be allocated.
- ✓ _____ the Project
You will need to confirm that the project is funded (i.e. there is money available for the project to start and continue).

- ✓ Create _____
Create or identify guidelines and policies for procurement and reimbursements.

- ✓ _____ the Project Budget
You will need to identify how the budget will be communicated and who will need to know if there are any issues if the budget is off-track.

- ✓ Identify the process for Monitoring and _____
You will need to identify who will be tracking the project budget and how the budget will be tracked.

Prayer Points:

1. Pray for wisdom regarding the estimated budget.
2. Pray for wisdom in communicating project budget needs.
3. Pray for wisdom in tracking the budget and communicating issues.

Questions for Discussion

1. If known, how much is the project budget?
2. When will the budget be effective?
3. Who will monitor the budget? How will the budget be tracked?
Who will need to be communicated with if costs exceed estimates?
4. Is the budget fully funded? Are shortfalls expected? How will your ministry project make up for that shortfall?
5. Should budget management be an objective in your project plan? If so, place it on the worksheet found on page 90,

Risk

A project "risk" is something that could get the project "off track" that might lead to the project being:

- _____ budget
- _____ scheduled events
- _____ quality
- _____ reaching objectives

There are many different types of risks such as:

- Poor project planning
- Unrealistic goals
- False assumptions regarding reliance on certain resources
- Organizational issues (i.e. change in senior leadership, direction or priorities).
- External risks (government regulation and environmental issues)

The following steps should be considered as you plan for risks to the project:

- ✓ _____ Risks
Determine what risks might affect the success of project. Although many things may happen during the life of a ministry project, you should focus your attention on _____ probability risks.
- ✓ Plan _____ to Risks
After identifying highly probable risks, your team should consider how to respond to these risks.
- ✓ Identify the Process for _____ and Tracking Risks
Your team should identify how risks will be identified, monitored, tracked and communicated to others.

Prayer Points:

1. Pray for wisdom regarding identifying and planning for project risks.
2. Pray for wisdom in mitigating risks.

Questions for Discussion

1. What obstacles or risks are there to the project?
2. What could your team do to help mitigate or minimize these risks?
3. Who will help identify additional risks?
4. Who will communicate risks to project sponsors and others?
5. Should risk management be an objective in your project plan? If so, place it on the worksheet found on page 90.

Quality and Measurement

Planning for quality can reduce re-work or missed objectives as the project progresses.

It is important to consider two important areas:

- ✓ Quality _____
Identifying what things are important to the success of the project and creating quality standards.

- ✓ Quality _____
Identifying the process for monitoring project results to determine if they comply with quality standards. You may need to plan for inspections (also called, reviews, audits or walkthroughs) or interviewing a sampling of target audience members.

Prayer Points:

1. Pray for wisdom in identifying issues regarding project quality.
2. Pray for wisdom in measuring results for quality purposes.

Questions for Discussion

1. How will you measure your project to determine if it is on track or successfully meeting objectives?
2. Who will be responsible for measuring and tracking project results?
3. Should quality management be an objective in your project plan? If so, place it on the worksheet found on page 90.

Change Management

Change management is the process of managing changes to the project.

In your initial project plan it can be helpful to identify:

- ✓ _____ will authorize changes to the project scope or plan?
Will an individual, the project team or a sub-group decide which changes to accept or reject?
- ✓ _____ will the change management process be handled?
Will there be documentation? Will there be sign-offs, etc.
For large projects a written "change request" may be necessary.

The written change request may identify the reason for the change such as:

- A new or unknown government regulation
 - An error or omission in planning for the project scope
 - A change that adds value
(i.e. new technology available)
 - Work-around due to a risk
- ✓ Who will communicate changes to the project team and others?
Communication regarding changes is vital for the project.

Prayer Points:

1. Pray for wisdom regarding project changes.
2. Pray for wisdom in identifying a process for handling project changes.

Questions for Discussion

1. Who will authorize changes to the project scope or plan?
2. How will the change management process be handled for your project?
3. Who will communicate project changes to the project team and others?
4. Should change management be an objective in your project plan? If so, place it on the worksheet found on page 90.

Chapter Review

Next Steps:

1. Meet with your Ministry Project team.
2. Review the initial project objectives.
3. Identify any additional objectives for the project in the areas of:
 - a. Authorization
 - b. Research
 - c. Communication
 - d. Budget
 - e. Risk
 - f. Quality
 - g. Change

Questions for Discussion:

1. How can a project plan be helpful?

2. Read the following scenario:

Recently, a ministry project team met to discuss starting a ministry to the poor. During the chartering phase they identified who they would serve. The team has a meeting scheduled tomorrow to discuss planning.

What next steps should the project leader and the project team consider?



Project Planning – Identifying Tasks

In this chapter you will:

- Discover additional components of the Project Planning phase of a ministry project

Chapter 6: Project Planning – Identifying Tasks

We noted earlier that there are typically five distinct phases to a ministry project:

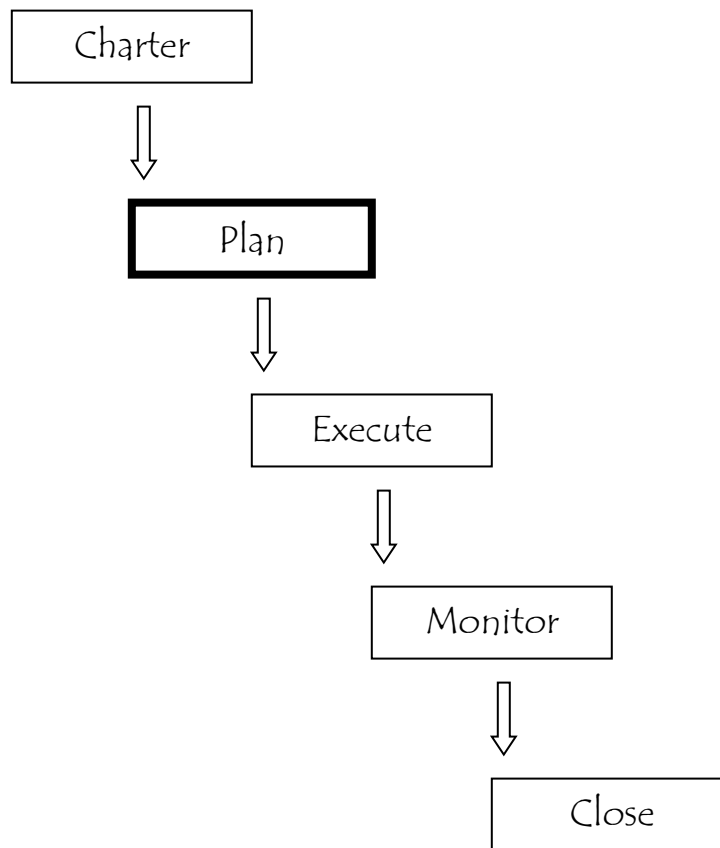

In this chapter we will explore the Project Planning phase in more detail.

Project Planning Overview

This phase involves _____ a plan to accomplish the ministry project.
In this phase you will answer the following about the project:

Confirm the major
ministry project

W_____

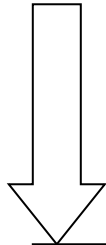

Identify the
necessary _____
for each objective

H_____

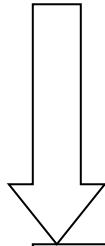

Identify _____ for
each project task

W_____

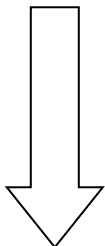

Identify the
_____ needed
for each task

W_____

Identifying the Project Tasks

The next step in planning your ministry project is answering an important question about the project:

W_____ tasks are involved in accomplishing the ministry project?

It is important that you identify the necessary _____ to accomplish the project. A task is an _____ in your project that has a beginning and an end and is necessary to accomplish the goals of your project.

For example, an objective in your project plan might be to receive authorization for the project. The _____ might be:

1. Identify project goals
2. Create project plan
3. Create a budget estimate
4. Meet with project sponsor
5. Receive approval

Another example might be in the planning of a newsletter (to help the others learn more about the ministry project). Each task might be _____ as follows:

#	Task Name
1.1	Create logo
1.2	Write newsletter content
1.3	Print newsletter
1.4	Add mailing labels
1.5	Take to Post Office

Duration

When creating a project plan, it can be helpful to identify the _____ of each task. The duration is how much _____ is required to complete the task in terms of minutes, hours, weeks or months.

In the example of the newsletter, you might fill in the following duration information:

#	Task Name	Duration
1.1	Create logo	2 days
1.2	Write newsletter content	5 days
1.3	Print newsletter	2 days
1.4	Add mailing labels	1 day
1.5	Take to Post Office	1 hr

Milestones

Milestones are _____ in a project that have duration of zero minutes.

For the newsletter communication, a milestone might be identified in the project plan to indicate when the newsletter is _____:

#	Task Name	Duration
1.1	Create logo	2 days
1.2	Write newsletter content	5 days
1.3	Print newsletter	2 days
1.4	Add mailing labels	1 day
1.5	Take to Post Office	1 hr
1.6	Newsletter finished	0 days

Project Phases

Once all tasks are identified you can then identify phases for the project.

On your project plan, you can create a *summary* _____ to easily identify tasks that are similar or will be done during the same time period.

Example of a Summary Task (called "Newsletter")

#	Task Name	Duration
1.0	Newsletter	10 days (total)
1.1	Create logo	2 days
1.2	Write newsletter content	5 days
1.3	Print newsletter	2 days
1.4	Add mailing labels	1 day
1.5	Take to Post Office	1 hr
1.6	Newsletter Complete	0 days

Prayer Points:

1. Pray for those on your project team.
2. Pray for wisdom as the project team works to identify project tasks.

Questions for Discussion

1. Select the project's first major objective listed on page 90. On the page that follows, identify the tasks that will be necessary to accomplish that objective.
2. What is the duration for each task identified? Enter the duration of each task listed on page 91.

Identifying the Project Timeline

The next step in planning your ministry project is answering:

W_____ should these tasks be accomplished?

Identifying the Timeline

In the project plan, it can be helpful to identify the _____ date of when a task will begin and a _____ date of when the task will end.

Constraints

When identifying the start and finish dates for tasks, it is important to identify any constraints that might exist for the task.

One common constraint for all tasks is that the task must fall within the start date and the finish date of the overall project.

You should also identify if the task must finish or start on a _____ day. If so, it should be identified as a constraint that must be considered in your project timeline.

Task Relationships

Put the following tasks in the likely order that they will be performed for a ministry project that involves constructing a new building:

- A. Have an Open House for the new building
- B. Hire an architect
- C. Receive authorization to begin project
- D. Carpet the floors

Task #1: _____

Task #2: _____

Task #3: _____

Task #4: _____

Many tasks within your project have *dependencies*, which means that one task is _____ upon another.

For example, if we were planning on constructing a building, there are many tasks that must be done first, such as "Hire an architect", before other tasks can be performed, such as "Have an Open House".

There are several types of relationships or dependencies that may exist:

Finish to Start Relationship – this is the most common dependency in a project. For example, if you are planning the construction of a building, you would plan for the builders to _____ pouring the foundation before they could _____ putting on a roof.

Start to Start Relationship – this type of relationship means that tasks could _____ at the _____ time. In the example of our planning for a new building, we could plan to start painting the office the same day we start painting the nursery.

Finish to Finish Relationship – this type of relationship means that tasks will need to _____ at the _____ time. This type of relationship is not as common. For a small group ministry, for example, you might plan on all groups ending on a specific date in the spring time, in order to start a new program in the summer.

Lag and Lead Time

Another thing to consider when scheduling tasks is lag time and lead time.

Lag time means that there will be a _____ after one task is completed and before another task begins. For example, once the painting is finished, we could plan on having a lag time of one day to let the paint dry before hanging the curtains.

Lead time means that tasks can _____, such as when a task might be able to start when its predecessor (the task that comes before it in the project plan) is _____ complete.

For example, if one person is printing a newsletter for a ministry project, we might plan on having another person start folding and placing address labels once the printing is 25% complete.

Prayer Points:

1. Pray for wisdom as the project team works to identify the project timeline.

Questions for Discussion

1. What is the date that the ministry project will start?
2. What date will the ministry project be finished?
3. Continue working with the tasks from the project's first major objective. On page 91, identify the start date and finish date for each of the tasks.
4. What is the predecessor (the task that comes before) for each task? Enter the number of the predecessor task on page 91.

Identifying the Resources

The next step in planning your ministry project is answering:

W_____ should responsible for accomplishing these tasks?

Resources are the people, equipment and material used to complete tasks.

Resource Planning

It is important to ask the project team to:

- Identify the resources (people/things) that are needed for the project

- Identify the availability of resources for the project.

Note: Many ministry projects utilize volunteers. It is important to understand each volunteer's schedule and level of commitment.

- Identify any other resource constraints.

- Identify the roles/tasks of the various people on the team.

- Ensure that people clearly understand their roles for the project.

Resource Development

You may also need to plan for training and development of volunteers and team members to ensure that each resource has the necessary skills to accomplish the task that they have been assigned.

Prayer Points:

1. Pray for those who will serve as volunteers on the project.
2. Pray for wisdom as the project team works to identify project resources.

Questions for Discussion

1. What resources are available to the ministry project?
2. When will those resources be available?
3. Continue working with the tasks from the project's first major objective. On page 91, identify the resources for each of the tasks.

Note: Once completed, you have created the initial Work Breakdown Structure (WBS) for the first objective for the ministry project.

Project Objectives - Worksheet

#	Objective/Goal
1	
2	
3	
4	
5	
6	
7	
8	
9	
10	
11	
12	
13	
14	
15	

Project Task – Worksheet

Objective #1: _____

#	Task Name	Duration	Start Date	End Date	Predecessors	Resource Name
1.1						
1.2						
1.3						
1.4						
1.5						
1.6						
1.7						
1.8						
1.9						
1.10						
1.11						
1.12						
1.13						
1.14						
1.15	Objective #1 Complete	0 days				

Project Task – Worksheet

Objective #2: _____

#	Task Name	Duration	Start Date	End Date	Predecessors	Resource Name
2.1						
2.2						
2.3						
2.4						
2.5						
2.6						
2.7						
2.8						
2.9						
2.10						
2.11						
2.12						
2.13						
2.14						
2.15	Objective #2 Complete	0 days				

Project Task – Worksheet

Objective #3: _____

#	Task Name	Duration	Start Date	End Date	Predecessors	Resource Name
3.1						
3.2						
3.3						
3.4						
3.5						
3.6						
3.7						
3.8						
3.9						
3.10						
3.11						
3.12						
3.13						
3.14						
3.15	Objective #3 Complete	0 days				

Project Task – Worksheet

Objective #4: _____

#	Task Name	Duration	Start Date	End Date	Predecessors	Resource Name
4.1						
4.2						
4.3						
4.4						
4.5						
4.6						
4.7						
4.8						
4.9						
4.10						
4.11						
4.12						
4.13						
4.14						
4.15	Objective #4 Complete	0 days				

Project Task – Worksheet

Objective #5: _____

#	Task Name	Duration	Start Date	End Date	Predecessors	Resource Name
5.1						
5.2						
5.3						
5.4						
5.5						
5.6						
5.7						
5.8						
5.9						
5.10						
5.11						
5.12						
5.13						
5.14						
5.15	Objective #5 Complete	0 days				

Project Task – Worksheet

Objective #6: _____

#	Task Name	Duration	Start Date	End Date	Predecessors	Resource Name
6.1						
6.2						
6.3						
6.4						
6.5						
6.6						
6.7						
6.8						
6.9						
6.10						
6.11						
6.12						
6.13						
6.14						
6.15	Objective #6 Complete	0 days				

Project Task – Worksheet

Objective #7: _____

#	Task Name	Duration	Start Date	End Date	Predecessors	Resource Name
7.1						
7.2						
7.3						
7.4						
7.5						
7.6						
7.7						
7.8						
7.9						
7.10						
7.11						
7.12						
7.13						
7.14						
7.15	Objective #7 Complete	0 days				

Project Task – Worksheet

Objective #8: _____

#	Task Name	Duration	Start Date	End Date	Predecessors	Resource Name
8.1						
8.2						
8.3						
8.4						
8.5						
8.6						
8.7						
8.8						
8.9						
8.10						
8.11						
8.12						
8.13						
8.14						
8.15	Objective #8 Complete	0 days				

Project Task – Worksheet

Objective #9: _____

#	Task Name	Duration	Start Date	End Date	Predecessors	Resource Name
9.1						
9.2						
9.3						
9.4						
9.5						
9.6						
9.7						
9.8						
9.9						
9.10						
9.11						
9.12						
9.13						
9.14						
9.15	Objective #9 Complete	0 days				

Project Task – Worksheet

Objective #10: _____

#	Task Name	Duration	Start Date	End Date	Predecessors	Resource Name
10.1						
10.2						
10.3						
10.4						
10.5						
10.6						
10.7						
10.8						
10.9						
10.10						
10.11						
10.12						
10.13						
10.14						
10.15	Objective #10 Complete	0 days				

Project Task – Worksheet

Objective #11: _____

#	Task Name	Duration	Start Date	End Date	Predecessors	Resource Name
11.1						
11.2						
11.3						
11.4						
11.5						
11.6						
11.7						
11.8						
11.9						
11.10						
11.11						
11.12						
11.13						
11.14						
11.15	Objective #11 Complete	0 days				

Project Task – Worksheet

Objective #12: _____

#	Task Name	Duration	Start Date	End Date	Predecessors	Resource Name
12.1						
12.2						
12.3						
12.4						
12.5						
12.6						
12.7						
12.8						
12.9						
12.10						
12.11						
12.12						
12.13						
12.14						
12.15	Objective #12 Complete	0 days				

Project Task – Worksheet

Objective #13: _____

#	Task Name	Duration	Start Date	End Date	Predecessors	Resource Name
13.1						
13.2						
13.3						
13.4						
13.5						
13.6						
13.7						
13.8						
13.9						
13.10						
13.11						
13.12						
13.13						
13.14						
13.15	Objective #13 Complete	0 days				

Project Task – Worksheet

Objective #14: _____

#	Task Name	Duration	Start Date	End Date	Predecessors	Resource Name
14.1						
14.2						
14.3						
14.4						
14.5						
14.6						
14.7						
14.8						
14.9						
14.10						
14.11						
14.12						
14.13						
14.14						
14.15	Objective #14 Complete	0 days				

Project Task – Worksheet

Objective #15: _____

#	Task Name	Duration	Start Date	End Date	Predecessors	Resource Name
15.1						
15.2						
15.3						
15.4						
15.5						
15.6						
15.7						
15.8						
15.9						
15.10						
15.11						
15.12						
15.13						
15.14						
15.15	Objective #15 Complete	0 days				

Chapter Review

Next Steps:

1. Meet with your Ministry Project team.
2. Review the project objectives.
3. Identify specific tasks to accomplish each objective.
 - a. Identify the duration of each task.
 - b. Identify the start and finish of each task.
 - c. Identify any relationships that exist between tasks.
 - d. Identify who will be assigned to work on each task.

Note: Chapter 5 (the previous chapter) has numerous examples of tasks necessary for completing common project objectives.

Questions for Discussion:

1. How can identifying each task in a ministry project plan be helpful?
2. Read the following scenario:

Recently, a ministry project team met to discuss their objectives for a ministry to the poor. During the planning phase they identified "Clear communication about the project" to those they are serving as a major objective.

The leader for the ministry project has a team meeting scheduled tomorrow with the team to discuss planning. What things should the team consider?



Project Execution and Monitoring

In this chapter you will:

- Discover important components of the Project Execution and Monitoring phase of a ministry project

Chapter 7: Project Execution and Monitoring

We noted earlier that there are typically five distinct phases to a ministry project:

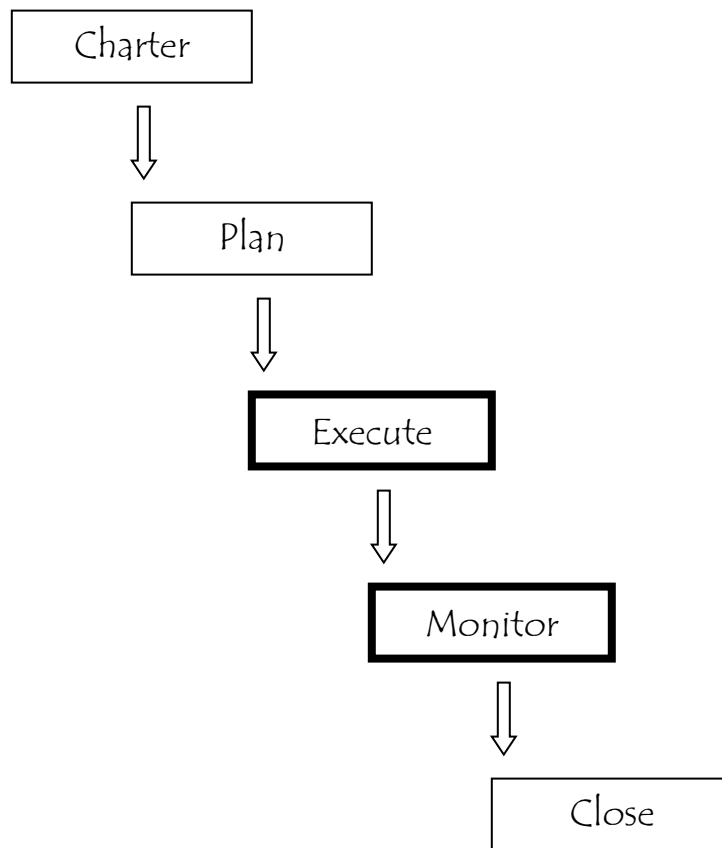

In this chapter we will explore the project execution and monitoring phases.

Project Execution and Monitoring Overview

This phase involves taking _____ on the project plan to accomplish the ministry project. In this phase you will do the following for the project:

Coordinate with resources to accomplish _____

D_____

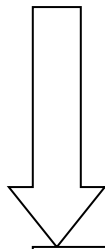

_____ the project based on objectives

Ch_____

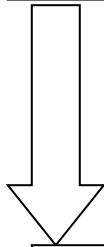

_____ the project if changes are necessary

Ch_____

Project Execution of Objectives and Goals

The execution phase of the ministry project involves:

C_____ and initiating the assigned work in the project plan.

The project execution phase of a ministry project involves the _____ of one or many people to accomplish the tasks that were planned.

In the project execution phase, work is done to accomplish the tasks to meet the project's objectives.

For example, your ministry project might see initial work done to:

- Construct a building
- Start a new church service
- Conduct an overseas missions trip
- Start a small group ministry
- Start a ministry to the poor
- Start a neighborhood small group
- Raise funds for a Christian school

For project leaders, _____ people and resources will be very important during this phase.

Project leaders may need to:

- Create "Progress Reports" or "_____ Reports" to identify and communicate the status of the ministry project to the project team, project sponsors and others.
- Create "_____ Requests" to identify changes to the project.
- For larger projects: solicit bids and proposals, chose contractors, and establish contracts.

Prayer Points:

1. Pray for those working on your project.
2. Pray for wisdom for project leaders as they coordinate resources and communicate project needs.

Questions for Discussion:

1. What tasks will be initiated first in your ministry project?

2. How much effort do you estimate will be involved in coordinating resources?

Project Monitoring of Objectives and Goals

The monitoring phase of the ministry project asks:

A_____ the objectives and tasks of the project being accomplished?

The project monitoring phase of a ministry project involves _____ the project based on planned objectives and measures and _____ the project if changes are necessary.

For project leaders, it will be necessary to manage the project's resources, cost, schedule, and quality.

Manage Project Resources

The goal of managing the project's resources means that the _____ resources are used the right way on project. In most ministry projects, the resources utilized are volunteers.

If resources are not managed properly, there may be confusion as to who will be accomplishing which tasks as well as tasks not being completed.

In working with resources it is important that project leaders:

- ✓ _____ people to work on the project
- ✓ Provide _____ on the skills needed to accomplish project tasks
- ✓ Communicate each person's _____ and responsibilities
- ✓ _____ that each person understands their responsibilities
- ✓ Identify any _____ to resource availability if there are changes to the project's quality, budget or schedule

- ✓ Help team members feel that they have accomplished something worthwhile.

- ✓ _____ the results of volunteers and encourage improved if needed

- ✓ Follow a communications _____ to ensure that all resources receive project updates (as needed)
 - Use a phone list/email list
 - Use an internal communication plan

Manage the Project Budget

The goal of managing to the project's budget is to keep expenses equal to or _____ what was budgeted. Or, if you are raising funds, to meet revenue targets.

After the team has created an estimate for the project and the project starts, project leaders will need to ensure that:

- ✓ The project is fully _____
 - For more complex projects, funding may occur in phases. Therefore, you will need to ensure that each phase is fully funded.
 - If the project is not fully funded, you will need to acquire funding or change the scope of the project.
- ✓ Ensure that _____ are followed
You will need to ensure that guidelines and policies for procurement and reimbursements are followed so that unexpected expenses are avoided.
- ✓ Discover cost _____
It is important to look for ways to eliminate extra costs that will not put project objectives at risk. This can be helpful because unexpected costs might arise with your project.
- ✓ Track _____
 - Computerized tools are available to help with complex projects.
- ✓ _____ revenue (if necessary)
 - Computerized tools are available to help with complex projects.

- ✓ _____ actual project expenses (or revenue) to budget estimate
This step is essential in ensuring that the project is on track.
 - Computerized spreadsheet tools are available to help with this comparison.

- ✓ Communicate Budget Status and Issues
Project leaders will need to communicate the budget status and budget issues to project sponsors and the project team.

Manage the Project's Schedule

The goal of managing the project's timeline is to ensure that tasks are done on time or _____ than what was planned.

After a project timeline has been created for the project and the project starts, project leaders will need to:

- ✓ Ensure that the project _____ is created
- ✓ Ensure the project timeline is reviewed frequently by the team
- ✓ Make sure that responsibility for completing tasks is _____ understood
- ✓ Communicate the necessity (or a sense of urgency) in getting things _____
 - It is helpful for people to understand how tasks are related to others.
- ✓ Establish clear communication with resources to uncover any _____ that may keep tasks from being accomplished on time.
- ✓ Communicate any _____ to the timeline if necessary and identify implications to other tasks if tasks are accomplished late.

Manage the Project's Quality

The goal of managing the project's quality means that expectations are met or exceeded.

If quality is not managed, tasks may be incomplete and not _____ the needs of those you are serving. Tasks done with low quality could also result in delays if the tasks need to be re-worked.

As project leaders manage the project's quality they will need to:

- ✓ Review the standards set during the _____ phase
During the planning phase, your team should have identified the things that are important to the project's success and come to mutually agreed upon standards.
- ✓ Clearly communicate project _____
- ✓ Monitor project results to determine if they comply with quality standards. You may need to:
 - conduct inspections (also known as reviews, audits or walkthroughs)
 - survey the target audience for feedback
 - complete evaluation checklists
- ✓ Take corrective _____ (such as have tasks reworked) if the project deliverables fall short of standards
- ✓ Identify risks to the project timeline if quality becomes an issue.

Adjusting the Project Plan

Project leaders will need to monitor the project and ask:

- Are we completing the tasks?
- Are we accomplishing the milestones that we planned?
- Are we on track?

If the project is not on-track, project leaders will need to _____ the reason(s) why the project is off-track, such as:

- ✓ The initial estimate was too optimistic
- ✓ Resources are unavailable to do the work
- ✓ Unexpected changes occurred to the scope of the project
- ✓ Quality of work is not complete or not acceptable

If things have changed from your original plans, prayerfully adjust the project plan as you proceed and communicate those adjustments to others.

Project leaders may need to:

- ✓ _____ resources
- ✓ _____ the schedule
- ✓ _____ the scope of the project

You will also want to carefully examine future tasks and identify potential issues and risks based on any changes made.

Prayer Points:

1. Pray for those working on your project as the project progresses.
2. Pray for wisdom in managing the project's people, budget, schedule and quality.

Questions for Discussion:

1. How can managing the project's resources be helpful?
2. How can managing the project's budget be helpful?
3. How can managing the project's schedule be helpful?
4. How can managing the project's quality be helpful?

Chapter Review

Next Steps:

1. After completing the project planning process, coordinate with resources to begin initiating work on the tasks in the project plan.
2. Monitor tasks.
3. Identify any risks to the project in terms of the project's:
 - a. Resources
 - b. Budget
 - c. Time/Schedule
 - d. Quality
4. Adjust the project plan if necessary.

Questions for Discussion:

1. What do you think will be the most challenging aspect of executing and monitoring a ministry project?
2. Read the following scenario:

A ministry project was one month into their project, when they were told that their budget would be reduced by 50% because of budget constraints.

The ministry team will be meeting today to discuss their next steps. What would you recommend?



Project Closeout

In this chapter you will:

- Discover important components of the Project Closeout phase of a ministry project

Chapter 8: Project Closeout

We noted earlier that there are typically five distinct phases to a ministry project:

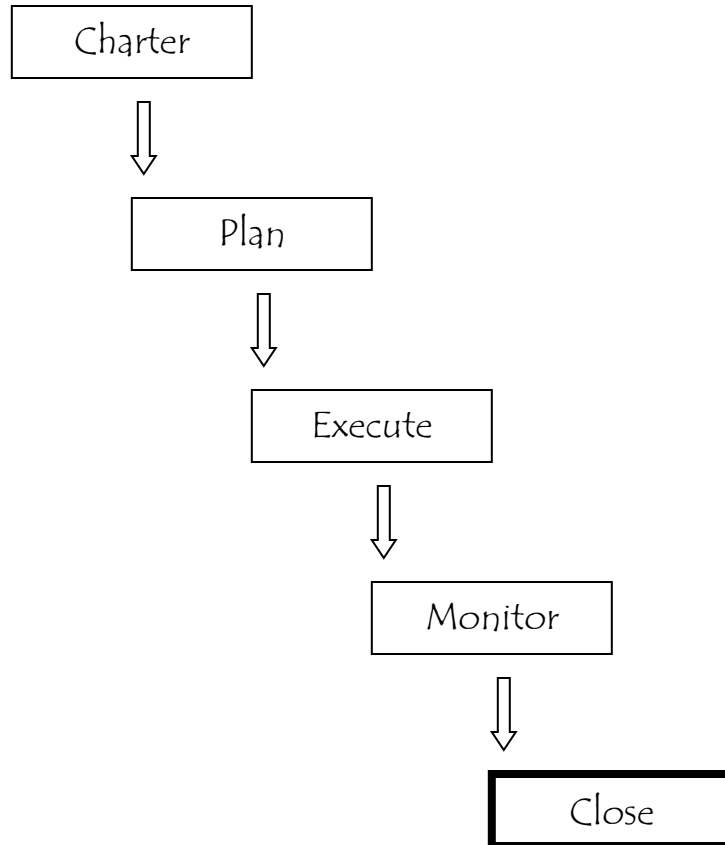

In this chapter we will explore the Project Closeout phase.

Project Closeout Overview

This phase involves _____ the project and transferring any knowledge or assignments to others. In this phase you will answer the following about the project:

Confirm that the major _____ were met.

C _____

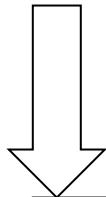

Identify lessons _____ in the project.

R _____

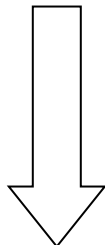

Provide recommendations for _____ projects.

S _____

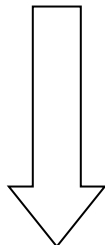

_____ with the project team and others.

R _____

Confirm that Project Objectives were met

The closeout phase of the ministry project asks:

W_____ the project objectives accomplished?

During the project closeout, you can _____ that:

- ✓ Resources have completed their work
- ✓ Expenditures are equal to or under budget estimates
- ✓ Tasks were completed on schedule
- ✓ Quality meets or exceeds expectations

For more complex projects you may need to:

- complete a financial _____ of project expenses and revenue
- have a formal " _____ " from the project sponsor
- have a _____ with suppliers, vendors or project sponsors to confirm that all project objectives were met

Note: Some ministry projects may terminate earlier than expected, due to many factors including: budget limitations, leadership changes, and problems during execution.

Even if the project terminates early, it is important to complete the remaining closeout phase steps (identifying lessons learned, providing recommendations for future projects and celebrating with the project team) found on the following pages.

Identify Lessons Learned in the Project

Another question you should ask during the closeout phase of the ministry project is:

W_____ lessons did we learn during the ministry project?

During the project closeout, you can _____:

- ✓ What did we learn about the people we were serving?
- ✓ What did we learn about the resources that did the work?
- ✓ What did we learn about our budget estimates and actual expenditures?
- ✓ What did we learn about our scheduling estimates and actual time spent?
- ✓ What did we learn about our expectations (regarding quality and other areas)?
- ✓ What changes did we expect or not expect? Why?
- ✓ What did we learn about God?
- ✓ What did we learn about ourselves?
- ✓ What would we do differently?
- ✓ What would we keep the same?

For more complex projects you may need to:

- Compile these findings and other project documents in a project history document called the "Project Library"
- Present these findings to the project sponsor or others

Provide Recommendations for Future Projects

Another question you should ask during the closeout phase of the ministry project is:

W_____ information do we need to share with others for future projects?

During the project closeout, you can _____:

- ✓ What important information do others need to know who might be doing similar ministry projects?

Sometimes you will need to focus on _____, which means collecting and sharing the information regarding your ministry project to others because they may need to:

- Continue the work that you started
- Start a similar ministry project

Celebrate with the Project Team and others

Completing a project can be a time of thanksgiving and celebration. You can thank God for His help and guidance in the ministry project.

During the project closeout, you can also _____ the people that contributed to the project. By:

- ✓ Writing a thank you note.
- ✓ Publicly recognizing the contribution of people
- ✓ Providing them with a token of appreciation.

Chapter Review

Next Steps:

1. Complete the project's objectives.
2. Schedule a formal closeout meeting (if necessary).
3. Confirm that the project's objectives were met.
4. With the project team, identify lessons learned in the project.
5. With the project team, provide recommendations for future projects.
6. Celebrate with the project team and others.

Questions for Discussion:

1. Why is the project closeout phase important to a ministry project?
2. Read the following scenario.

Upon completion of a ministry project, the project's leader decided to collect "lessons learned" from the ministry project team.

What would you recommend as the best method for collecting this information?

Project Leadership



In this chapter you will:

- Analyze your preferences for ministry project leadership
- Create a plan for further growth

Ministry Project Leadership

Leadership is a vital component to any ministry project.



At the start of our training we listed several important questions that you might be asking, such as:

- What potential do I have for managing ministry projects?
- Does God really want me to lead ministry projects?
- What difference can I make in a ministry project?
- How could I best serve on a ministry team?

These are important questions, which need to be prayerfully considered. Hopefully you have received more clarity around the answers to these questions as you have participated in this training program.

As you consider leadership for a ministry project, there are several areas that you should work to develop, including:

- ✓ L_____ – a ministry project is all about serving the Lord. It is important to continue to cultivate a relationship with Him through prayer, worship and study.
- ✓ L_____ – a ministry project is also all about helping other people. It is important to consider the affect of your actions and the project on others. As the Apostle Paul encouraged, we should “Do everything in love.” (1 Cor. 16:14).

- ✓ **P** _____ – the ability to identify and solve problems is very important for project leaders. This capability requires a combination of project knowledge and analytical skills.

To grow in this area, ask other leaders about the types of problems they have faced and how they decided on the best course of action.

As you work to solve problems with your project team, it can be helpful to differentiate between the symptoms of a problem and the problem itself.

- ✓ **T** _____ – the ability to see projects through until the end is also very important for project leaders. We have mentioned that ministry project can be difficult. It is important to continue to work through issues as long as the Lord is calling you to work on the project.

- ✓ **C** _____ – the ability to communicate clearly to others is an important skill for project leaders.

To grow in this area, it can be helpful to work with a mentor or other ministry leader to receive feedback and help clarify the message you will deliver to others.

Project Leadership Development Plans

Growing as a ministry leader is a life-long process. The following is designed to help you as you plan for future growth in project leadership.



Refer back to page 34 and enter the totals from the assessment again:

Totals for Line A (People): _____

Totals for Line B (Budget): _____

Totals for Line C (Schedule): _____

Totals for Line D (Quality): _____

Questions for Discussion – Analysis of Your Highest Area

1. Which area did you score the highest in?
2. How can others be served by ministry leaders focusing on this area?
3. Are you surprised that you scored highest in this area? Why?
4. What will you need to do as a leader to ensure that you continue to focus on this area?

Questions for Discussion

– Analysis of Your Least Preferable Area

1. Which area did you score the lowest in?
2. Are you surprised that you scored lowest in this area? Why?
3. What might be some reasons you chose other areas instead of this one?
4. What might you need to do as a project leader to grow in this area?

Personal Reflection: Course wrap up

1. What are the most important lessons you learned in this training course?

2. What actions will you need to put into place to incorporate those lessons into your life?
